



Structural Calculations For:

# Rainier 9118

Mercer Island, Washington



Prepared for: William E. Buchan, Inc.

Job #: 01011-2021-06

Date: September 10, 2021



**SEATTLE  
TACOMA**

2124 Third Avenue, Suite 100, Seattle, WA 98121  
934 Broadway, Suite 100, Tacoma, WA 98402

○ 206.443.6212  
○ 253.284.9470

⊕ [ssfengineers.com](http://ssfengineers.com)

# Criteria Sheet

## Codes

Structural IBC 2018  
 Loading ASCE 7-16  
 Wood: NDS 2018  
 Steel: AISC 360-16  
 Concrete: ACI 318-14  
 Masonry: TMS 402/602-16

## Project Location

Street & Number 4215 Mercerwood Drive  
 City: Mercer Island State: WA  
 ZIP: 98040  
 Latitude: 47.5729 N  
 Longitude: -122.2076 W  
 Ground Elevation 193 ft

## Occupancy Category

Risk Category: II ASCE 7 Table 1.5-1

## Seismic Load Summary:

Analysis Procedure: Equivalent Lateral Force Procedure  
 Lateral System: Light-frame (wood) Walls Sheathed with Wood  
 Structural Panels Rated for Shear Resistance  
 R: 6.50  $C_d = 4$   
 Base Shear V = 28 kips  $\Omega_o = 2.5$   
 $S_s = 1.405$   $S_1 = 0.488$   
 $S_{DS} = 1.12$   $S_{D1} = 0.59$   
 $C_s = 0.173$   $I_e = 1.0$



## Story Information

# Stories Above Grade (Including Mezzanine Levels) 3

## Horizontal and Vertical Irregularities:

Is the building a "Regular Structure"? (No horizontal or vertical irregularities) No

## Wind Load Summary:

V = 98  $K_{z1} = 1.30$   
 Exposure = C

## Dead Loads:

Roof			Wall		
Roofing	2.5	psf	Siding	2	psf
1/2" Sheathing	1.5	psf	1/2" Sheathing	1.5	psf
Rafters/Trusses	2	psf	Framing	2	psf
Insulation	1	psf	Insulation	1	psf
5/8" GWB	3.1	psf	1/2" GWB	2.5	psf
Misc./Mech.	2	psf		9	psf
	12.1	psf	Use	10	psf
Use	15	psf			
Floor					
Flooring	1	psf			
3/4" Sheathing	2.3	psf			
Joists	2.6	psf			
5/8" GWB	3.1	psf			
Misc./Mech.	1	psf			
	10	psf			
Use	10	psf			

## Live Loads:

Snow 25 psf  
 Floor 40 psf

## Soils:

Soils Report Provided? Yes

Allowable Bearing	2000	psf	Active	35	pcf (Unrestrained)
Sliding, $\mu$	0.35		Seismic Surcharge	8H	psf
Passive	300	pcf	Traffic Surcharge	70	psf

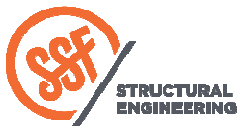

Rainier 9118

Mercer Island, Washington

DATE 8/13/2021

PROJ. #

DESIGN JDT

SHEET CR1



# Wind Design - MWFRS

ASCE 7 Chapter 27 - Directional Procedure

Design Method	ASD
---------------	-----

### Wind Coefficients

Exposure	C	
V=	98	mph
$K_d$ =	0.85	Table 26.6-1
$K_m$ =	0.99	Table 26.10-1
$K_e$ =	0.99	Table 26.9-1
G=	0.85	26.9.4

### Transverse Wind Pressures

L/B = 0.95 h/L = 0.51

Pressure Coefficients from Figure 27.3-1:

Bldg Face	$C_p$
Windward Wall	0.8
Leeward Wall	-0.50
Windward Roof	-0.91 / -0.18
Leeward Roof	-0.51

### Location and Building Dimensions

Calculate $K_{zt}$ ?	No	
$K_{zt}$	1.30	
Roof Type	Monoslope	
Roof Angle - Transverse Dir	0	degrees
Roof Angle - Long Dir	0	degrees
Ground to top of roof	33.5	ft
Bot of roof to top of roof	3.25	ft
Mean Roof Height, h	31.875	ft
Short Plan Dimension	62	ft
Long Plan Dimension	65.5	ft
Parapet ?	No	
Ground to top of parapet		ft
Average Parapet Height		ft
Ht of 2nd Level Above Grade	0	ft

Velocity Pressure at Mean Roof Height, $q_n$ =	26.8	psf
--	------	-----

### Wall Pressures (Unfactored):

ASD

Ht	$K_z$	$q_z$	$P_{ww \text{ walls}}$	$P_{lw \text{ walls}}$	$P_{\text{walls (psf)}}$
0-15	0.85	22.93	15.59	11.41	16.2
15-20	0.9	24.28	16.51	11.41	16.8
20-25	0.94	25.36	17.24	11.41	17.2
25-30	0.98	26.44	17.98	11.41	17.6
30-40	1.04	28.06	19.08	11.41	18.3
41-50	1.09	29.41	20.00	11.41	18.8
51-60	1.13	30.49	20.73	11.41	19.3
61-70	1.17	31.57	21.46	11.41	19.7
71-80	1.21	32.64	22.20	11.41	20.2
81-90	1.24	33.45	22.75	11.41	20.5
91-100	1.26	33.99	23.12	11.41	20.7

### Roof Pressures (Unfactored)

ASD

Windward		Leeward	Horiz Proj (psf)
Max	Min		
-4.1	-20.8	-11.5	4.80

### Longitudinal Wind Pressures

L/B = 1.06 h/L = 0.49

Pressure Coefficients from Figure 27.4-1:

Bldg Face	$C_p$
Windward Wall	0.8
Leeward Wall	-0.49
Windward Roof	-0.9 / -0.18
Leeward Roof	-0.50

### Wall Pressures (Unfactored):

ASD

Ht	$K_z$	$q_z$	$P_{ww \text{ walls}}$	$P_{lw \text{ walls}}$	$P_{\text{walls (psf)}}$
0-15	0.85	22.93	15.59	11.15	16.05
15-20	0.9	24.28	16.51	11.15	16.60
20-25	0.94	25.36	17.24	11.15	17.04
25-30	0.98	26.44	17.98	11.15	17.48
30-40	1.04	28.06	19.08	11.15	18.14
41-50	1.09	29.41	20.00	11.15	18.69
51-60	1.13	30.49	20.73	11.15	19.13
61-70	1.17	31.57	21.46	11.15	19.57
71-80	1.21	32.64	22.20	11.15	20.01
81-90	1.24	33.45	22.75	11.15	20.34
91-100	1.26	33.99	23.12	11.15	20.56

### Roof Pressures (Unfactored)

ASD

Windward		Leeward	Horiz Proj (psf)
Max	Min		
-4.1	-20.5	-11.4	4.80



Rainier 9118

Mercer Island, Washington

DATE 8/13/2021

PROJ. #

DESIGN JDT

SHEET CR3

## LATERAL ANALYSIS

### SEISMIC DESIGN

ROOF DIA.: 15 PSF x 1,955 SQ.FT. + 5 PSF x 1,601 SQ. FT. = 37.3 KIPS

UPPER FLOOR DIA.: 20 PSF x 1,601 SQ. FT. + 25 PSF x 205 PSF + 15 PSF x 2,220 SQ. FT. + 5 PSF x 1,326 SQ. FT. = 77.1 KIPS

MAIN FLOOR DIA: 20 PSF x 2,437 SQ. FT. = 48.7 KIPS

**BASE SHEAR = 25.7 KIPS**

### WIND DESIGN

ROOF DIA.: 18.30 PSF x 3.5 FT. + 17.60 PSF x 2.25 FT. = 104 PLF

UPPER FLOOR DIA.: 17.60 PSF x 2.75 FT. + 17.20 PSF x 5 FT. + 16.80 PSF x 3.75 FT. = 197 PLF

LOW ROOF DIA.: 16.20 PSF x 6.75 FT. = 109 PLF

MAIN FLOOR DIA.: 16.80 PSF x 1.25 FT. + 16.20 PSF x 9.75 FT. = 179 PLF

DIRECTION	LEVEL	PLF	WIDTH	FORCE
E/W	ROOF DIA.	104 PLF	43.25 FT.	4.5 KIPS
E/W	UPPER FLOOR DIA.	197 PLF	43.25 FT.	8.5 KIPS
E/W	LOW ROOF DIA.	109 PLF	22.25 FT.	2.4 KIPS
N/S	ROOF DIA.	104 PLF	45.5 FT.	4.7 KIPS
N/S	UPPER FLOOR DIA.	197 PLF	45.5 FT.	9.0 KIPS
N/S	LOW ROOF DIA.	109 PLF	16.5 FT.	1.8 KIPS
N/S	MAIN FLOOR DIA.	179 PLF	47.5 FT.	8.5 KIPS

**E/W BASE SHEAR = 15.4 KIPS**

**N/S/ BASE SHEAR = 24.0 KIPS**

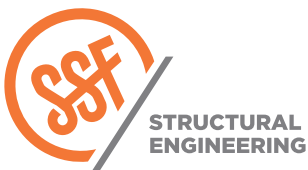

**RAINIER 9118**

PROJECT  
**MERCER ISLAND, WASHINGTON**

DATE

PROJ. # **JDT**

DESIGN **L1**

SHEET

# LATERAL DESIGN KEY PLAN

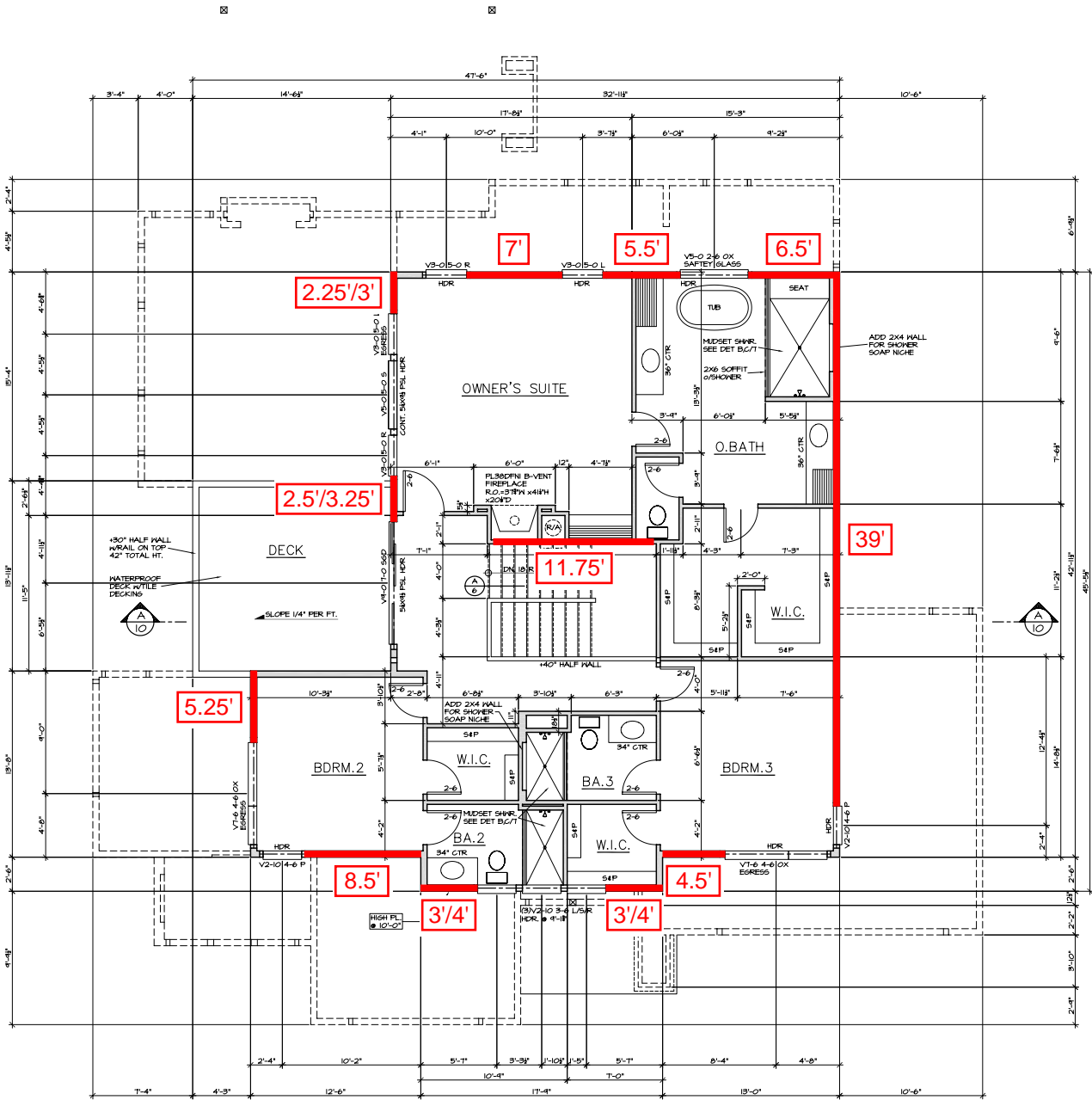

# UPPER FLOOR PLAN

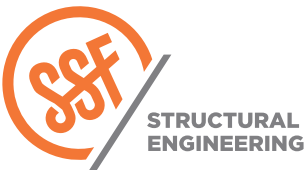

**RAINIER 9118**  
 PROJECT  
**MERCER ISLAND, WASHINGTON**

DATE \_\_\_\_\_  
 PROJ. # **JDT**  
 DESIGN **L2**  
 SHEET \_\_\_\_\_

# LATERAL DESIGN KEY PLAN

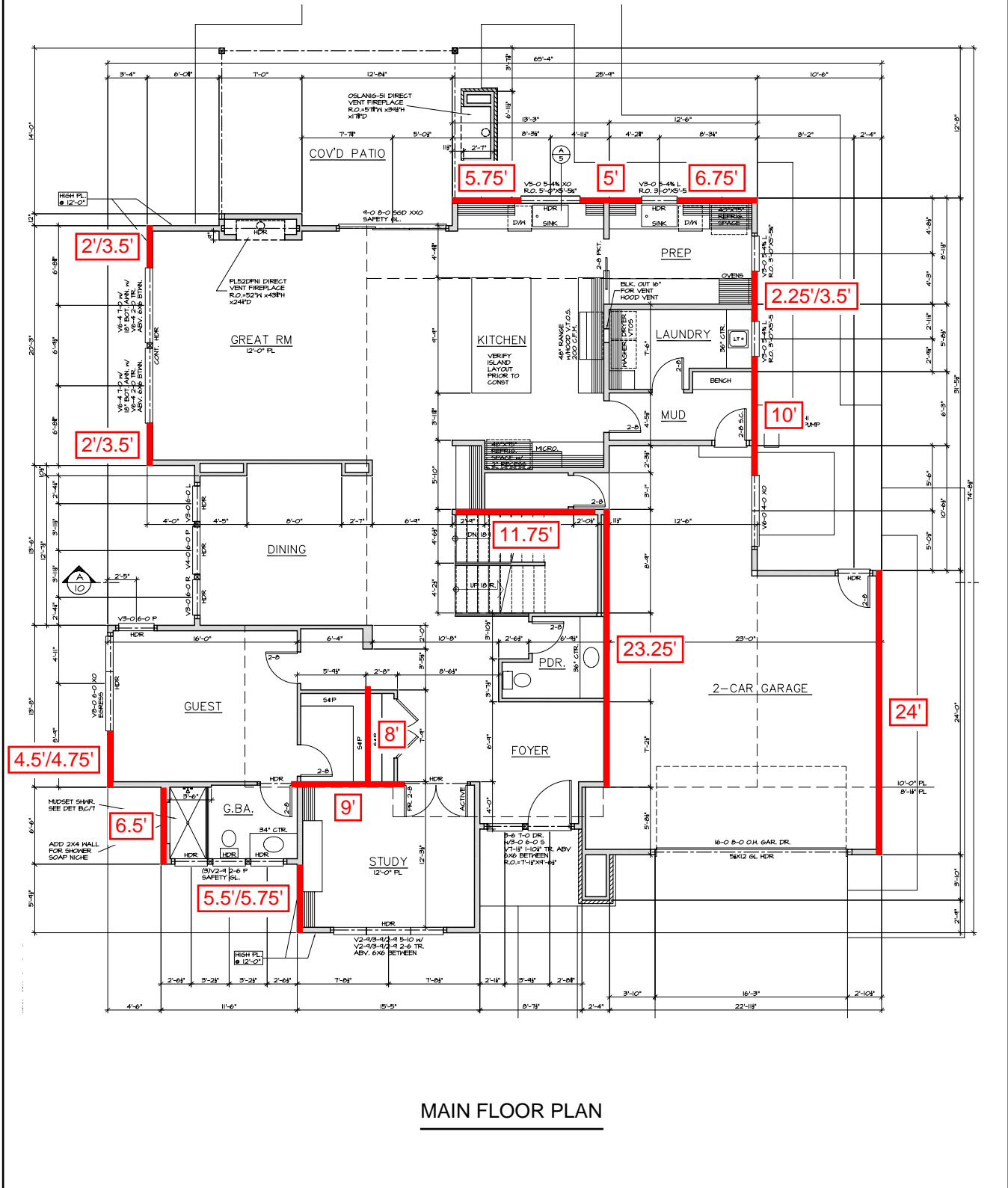

MAIN FLOOR PLAN

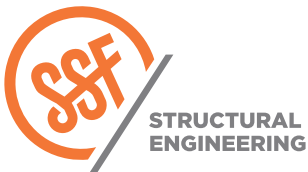

**RAINIER 9118**  
PROJECT  
**MERCER ISLAND, WASHINGTON**

DATE	
PROJ. #	<b>JDT</b>
DESIGN	<b>L3</b>
SHEET	

LATERAL DESIGN KEY PLAN

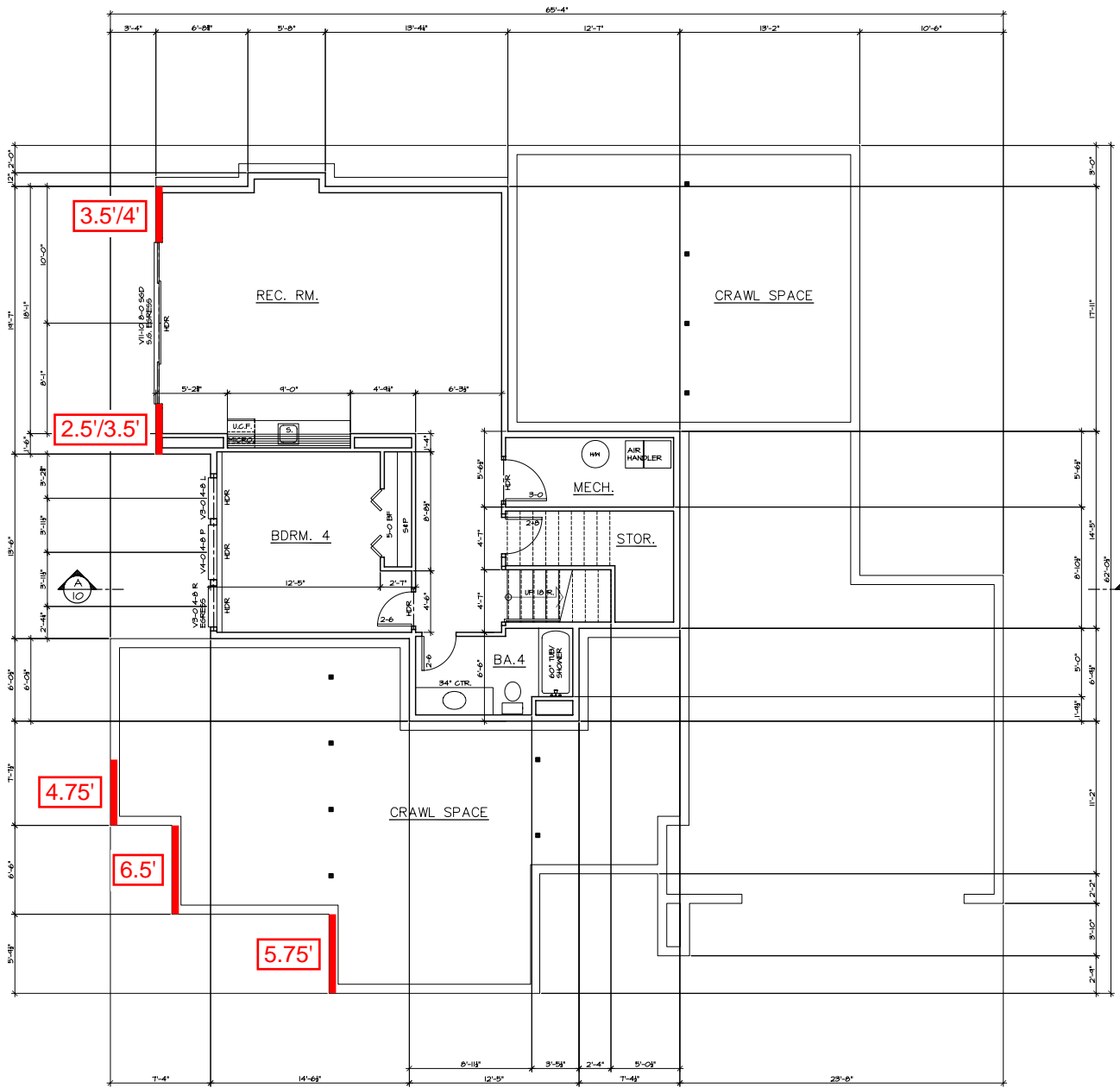

LOWER FLOOR PLAN

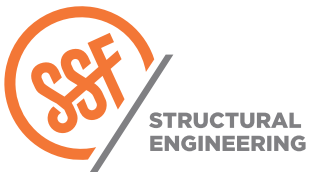

**RAINIER 9118**  
 PROJECT  
 MERCER ISLAND, WASHINGTON

DATE	
PROJ. #	JDT
DESIGN	L4
SHEET	



LATERAL DESIGN

E/W DIRECTION - SEISMIC DESIGN

ROOF DIA:	(S)	(N)	
FORCE (KIPS)	0.5 K	4.5 K	4.0 K
SHEARWALL LENGTH (FT.)	5.25 FT.	4.75 FT. /6.25 FT.	39 FT.
SHEAR (PLF)	95 PLF	947 PLF	103 PLF
SHEARWALL TYPE	W6	2W2	W6
OVERTURNING (KIPS)	0.8 K - 0.6 DL	5.8 K - 0.6 DL	0.8 K - 0.6 DL
HOLDOWN TYPE	CS16	(3)CS16	NONE

E/W DIRECTION - SEISMIC DESIGN

UPPER FLOOR DIA:	(S)	(N)			
FORCE (KIPS)	2.5 K	9.5 K	2.4 K	5.7 K	1.7 K
SHEARWALL LENGTH (FT.)	20.5 FT./24 FT.	8 FT.	23.25 FT.	12.25 FT. /13.5 FT.	24 FT.
SHEAR (PLF)	122 PLF	1,187 PLF	103 PLF	465 PLF	71 PLF
SHEARWALL TYPE	W6	2W2	W6	W2	W6
OVERTURNING (KIPS)	1.3 K - 0.6 DL	11.9 K - 0.6 DL	1.0 K - 0.6 DL	4.2 K - 0.6 DL	0.7 K - 0.6 DL
HOLDOWN TYPE	CS16/HDU2	HDU11	HDU2	HDU4	NONE

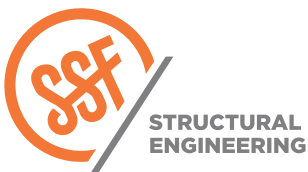

RAINIER 9118

PROJECT  
MERCER ISLAND, WASHINGTON

DATE

PROJ. # JDT

DESIGN L5

SHEET

LATERAL DESIGN

E/W DIRECTION - SEISMIC DESIGN

MAIN FLOOR DIA:

(S)



(N)

FORCE (KIPS)

3.7 K

SHEARWALL LENGTH (FT.)

23 FT./24.5 FT.

SHEAR (PLF)

161 PLF

SHEARWALL TYPE

W6

OVERTURNING (KIPS)

2.7 K - 0.6 DL

HOLDOWN TYPE

HDU4

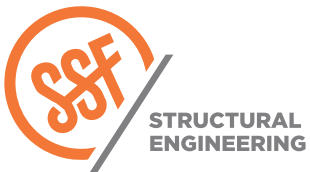

RAINIER 9118

PROJECT  
MERCER ISLAND, WASHINGTON

DATE

PROJ. # JDT

DESIGN L6

SHEET

LATERAL DESIGN

N/S DIRECTION - SEISMIC DESIGN

ROOF DIA:	(W)		(E)
FORCE (KIPS)	1.8 K	4.5 K	2.7 K
SHEARWALL LENGTH (FT.)	19 FT.	11.75 FT.	19 FT./21 FT.
SHEAR (PLF)	95 PLF	383 PLF	142 PLF
SHEARWALL TYPE	W6	W3	W6
OVERTURNING (KIPS)	0.8 K - 0.6 DL	3.1 K - 0.6 DL	1.3 K - 0.6 DL
HOLDOWN TYPE	CS16	(2)CS16	CS16

N/S DIRECTION - SEISMIC DESIGN

UPPER FLOOR DIA:	(W)		(E)
FORCE (KIPS)	5.4 K	8.2 K	8.3 K
SHEARWALL LENGTH (FT.)	17.5 FT.	11.75 FT.	9 FT.
SHEAR (PLF)	309 PLF	698 PLF	922 PLF
SHEARWALL TYPE	W4	2W3	2W2
OVERTURNING (KIPS)	3.1 K - 0.6 DL	10.1 K - 0.6 DL	10.5 K - 0.6 DL
HOLDOWN TYPE	HDU4	(2)CMST14/HDU11	HDU11

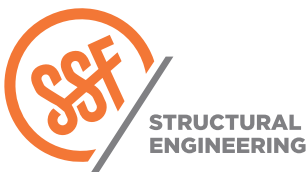

RAINIER 9118

PROJECT  
MERCER ISLAND, WASHINGTON

DATE

PROJ. # JDT

DESIGN L7

SHEET

GRAVITY DESIGN KEY PLAN

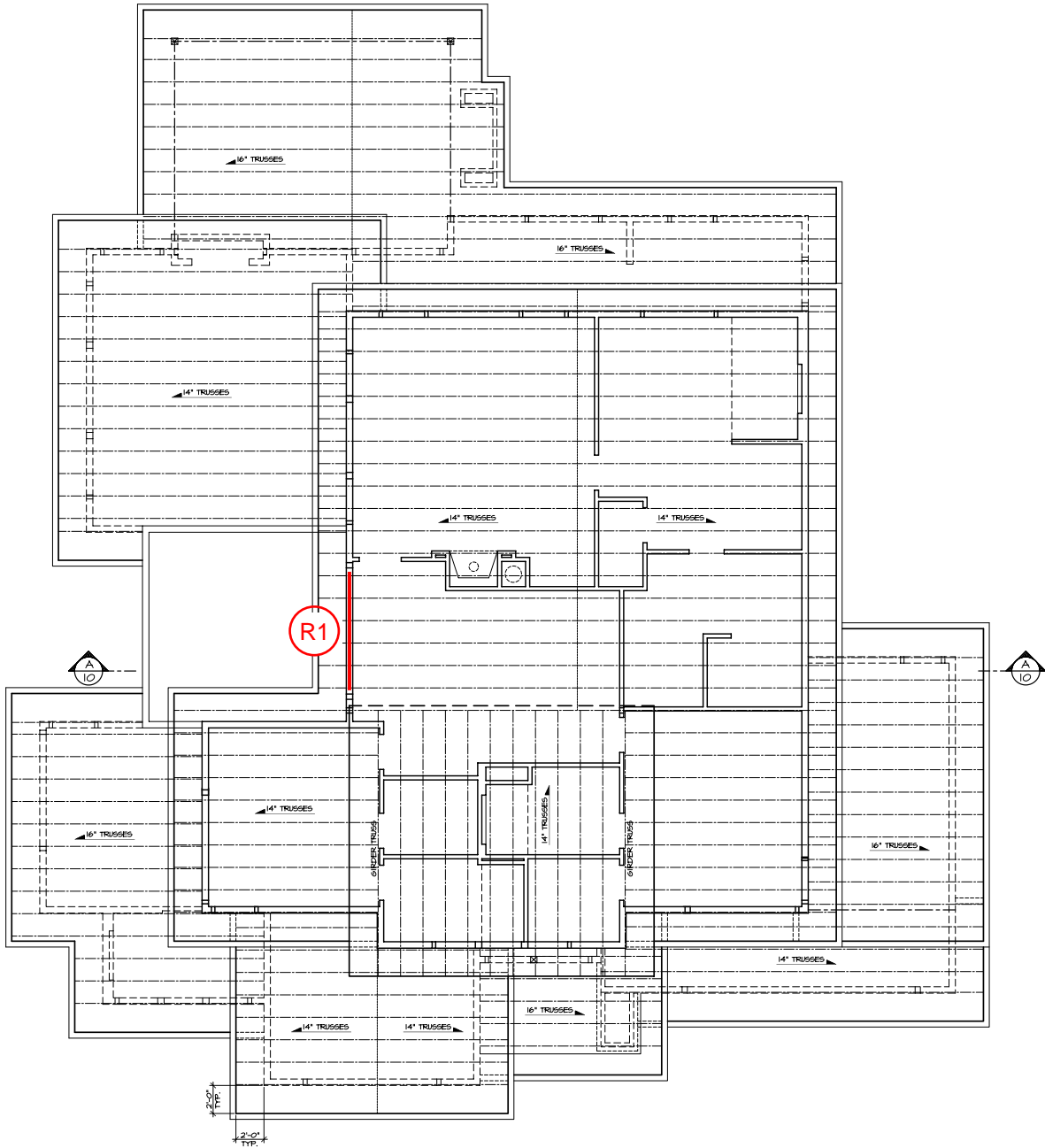

ROOF FRAMING PLAN

SEATTLE 2124 Third Ave, Suite 100, Seattle, WA 98121 | 206.443.6212  
 TACOMA 934 Broadway, Suite 100, Tacoma, WA 98402 | 253.284.9470

ssfengineers.com

SWENSON SAY FAGÉT

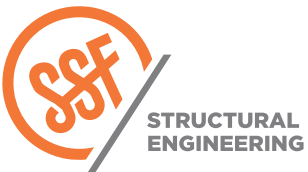

**RAINIER 9118**  
 PROJECT  
**MERCER ISLAND, WASHINGTON**

DATE	
PROJ. #	<b>JDT</b>
DESIGN	<b>G1</b>
SHEET	

Header		R1			4x10
w=	500	plf		R=	2,313 lbs
L=	9.25	ft		M=	5,348 ft-lbs
b=	3.50	in		Fb=	1,286 psi
d=	9.25	in		Fv=	89 psi
E=	1700	ksi		$\Delta$ =	0.21 in
Cv=	1.00	$\leq 1.0$		I/	529

2124 Third Avenue . Suite 100 . Seattle . WA 98121  
 www.swensonsayfaget.com  
 Office: 206.443.6212  
 Fax: 206.443.4870

Project: Rainer 9118 Date: 08/19/21  
Mercer Island, Washington Project #: \_\_\_\_\_  
Roof Framing Design: JDT  
 Sheet: G2

GRAVITY DESIGN KEY PLAN

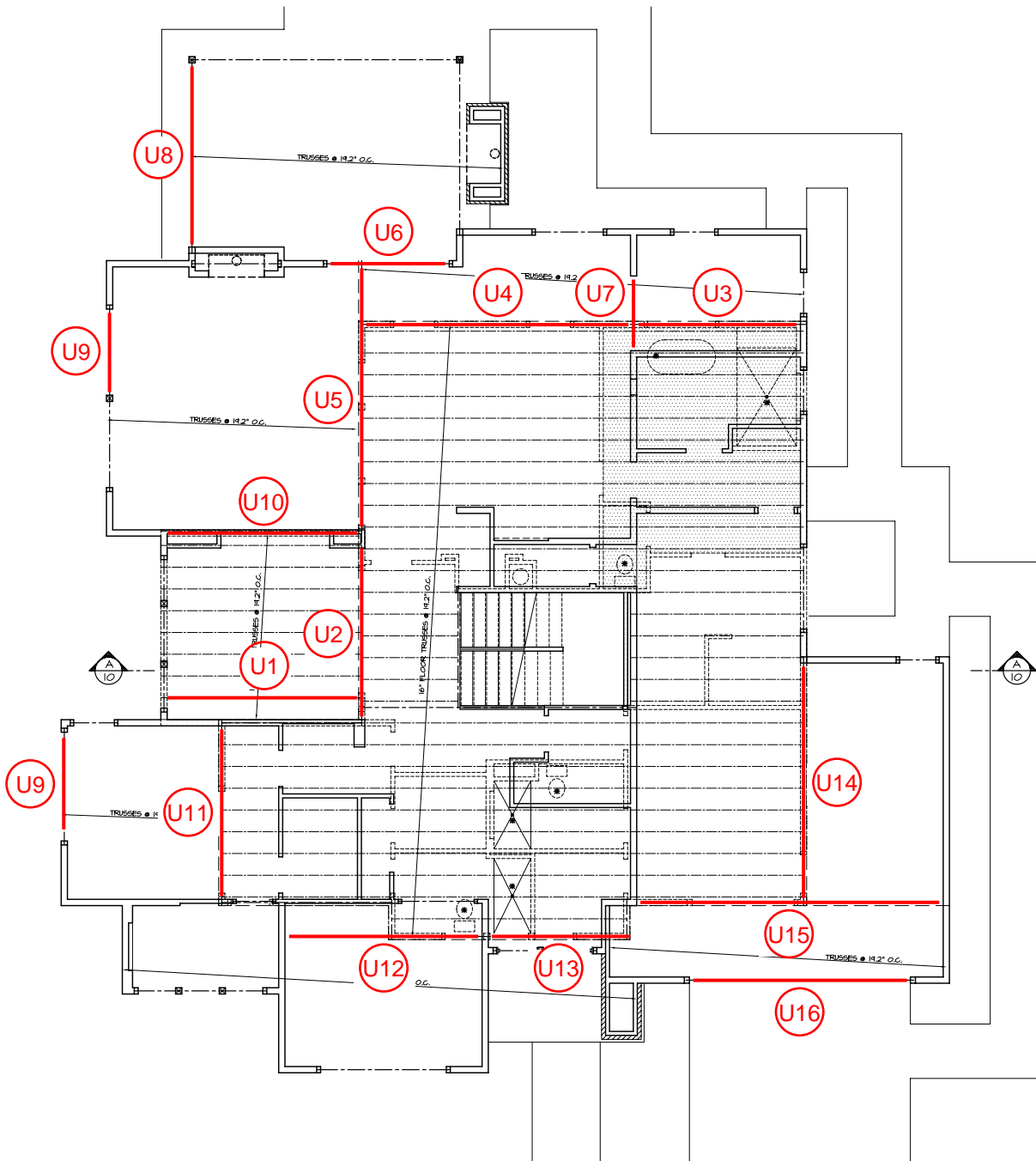

UPPER FLOOR FRAMING PLAN

SEATTLE 2124 Third Ave, Suite 100, Seattle, WA 98121 | 206.443.6212  
 TACOMA 934 Broadway, Suite 100, Tacoma, WA 98402 | 253.284.9470  
 SWENSON SAY FAGÉT [ssfengineers.com](http://ssfengineers.com)

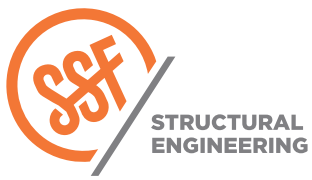

**RAINIER 9118**  
 PROJECT  
 MERCER ISLAND, WASHINGTON

DATE \_\_\_\_\_  
 PROJ. # **JDT**  
 DESIGN **G3**  
 SHEET \_\_\_\_\_

Joist		U1		P.T. (2)2x12 @ 16" oc	
w=	107	plf		R=	776 lbs
L=	14.5	ft		M=	2,812 ft-lbs
b=	3.00	in		Fb=	533 psi
d=	11.25	in		Fv=	30 psi
E=	1300	ksi		$\Delta$ =	0.23 in
Cv=	1.00	$\leq 1.0$		I/I	757

2124 Third Avenue . Suite 100 . Seattle . WA 98121  
 www.swensonsayfaget.com  
 Office: 206.443.6212  
 Fax: 206.443.4870

Project: Rainer 9118 Date: 08/25/21  
Mercer Island, Washington Project #: \_\_\_\_\_  
Upper Floor Framing Design: JDT  
 Sheet: G4

## SINGLE-SPAN BEAM ANALYSIS

For Simple, Propped, Fixed, or Cantilever Beams

Job Name: <b>Rainier 9118</b>	Subject: <b>Upper Floor Framing - U2</b>
Job Number: <b>01011-2021-06</b>	Originator: <b>JDT</b> Checker: <b>JDT</b>

**Input Data:** PSL 5 1/4x16      fb = 2084 psi      fv = 304 psi

**Beam Data:**

Span Type?	Simple
Span, L =	14.0000 ft.
Modulus, E =	2200 ksi
Inertia, I =	1792.00 in.^4

**Nomenclature**

**Beam Loadings:**

**Full Uniform:** w =  kips/ft.

	Start		End	
	b (ft.)	Wb (kips/ft.)	e (ft.)	We (kips/ft.)
#1:	0.0000	1.7380	4.2500	1.7380
#2:	4.2500	1.3550	13.0000	1.3550
#3:	13.0000	1.2600	14.0000	1.2600
#4:				
#5:				
#6:				
#7:				
#8:				

**Results:**

**Reactions:**

RL =	11.43 k	RR =	17.01 k
ML =	N.A.	MR =	N.A.

**Maximum Moments:**

+M(max) =	38.91 ft-k	@ X =	7.23 ft.
-M(max) =	0.00 ft-k	@ X =	0.00 ft.

**Maximum Deflections:**

-Δ(max) =	-0.357 in.	@ X =	7.07 ft.
+Δ(max) =	0.000 in.	@ X =	0.00 ft.
Δ(ratio) =	L/471		

**Point Loads:**

	a (ft.)	P (kips)
#1:	13.0000	7.94
#2:		
#3:		
#4:		
#5:		
#6:		
#7:		
#8:		
#9:		
#10:		
#11:		
#12:		
#13:		
#14:		
#15:		

**Moments:**

	c (ft.)	M (ft-kips)
#1:		
#2:		
#3:		
#4:		

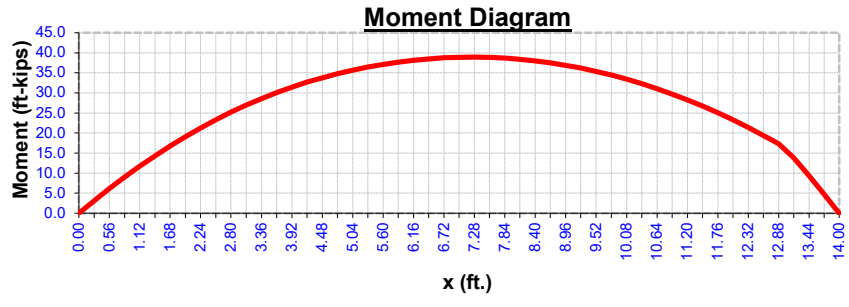
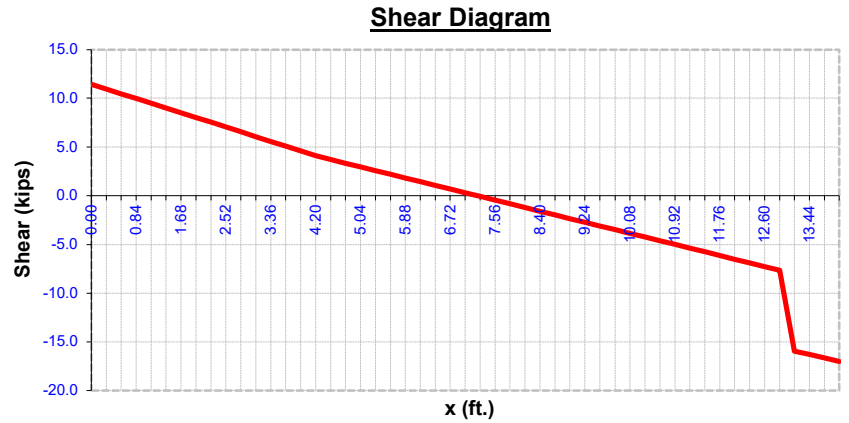



Beam		U3		LSL 3 1/2x16	
w=	327	plf		R=	2,044 lbs
L=	12.5	ft		M=	6,387 ft-lbs
b=	3.50	in		Fb=	513 psi
d=	16.00	in		Fv=	43 psi
E=	1500	ksi		$\Delta$ =	0.10 in
Cv=	1.00	$\leq 1.0$		I/	1496

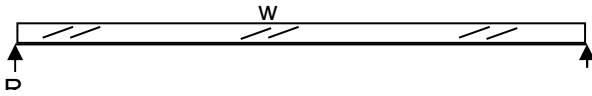

Header		U6		LSL 3 1/2x16	
w1=	180	plf		R1 =	11,769 lbs
w2=	180	plf		R2 =	5,302 lbs
L1=	3	ft		M =	31,685 lb-ft
L2=	7	ft		Fb =	2,546 psi
X=	4.3	ft		Fv =	309 psi
P=	15,361	lbs		$\Delta$ =	0.22 in
b=	3.50	in		I/	507
d=	16.00	in		Cv=	1.00
E=	1,500	ksi			

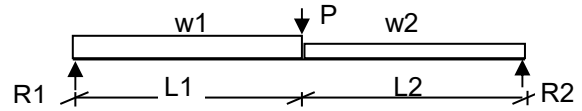

Beam		U4		GL 5 1/2x24	
w=	327	plf		R=	3,270 lbs
L=	20	ft		M=	16,350 ft-lbs
b=	5.50	in		Fb=	372 psi
d=	24.00	in		Fv=	30 psi
E=	1800	ksi		$\Delta$ =	0.10 in
Cv=	0.93	$\leq 1.0$		I/	2325

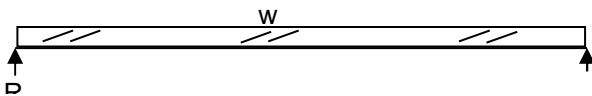

Header		U7		LSL 3 1/2x11 7/8	
w1=	660	plf		R1 =	4,319 lbs
w2=	1,480	plf		R2 =	6,800 lbs
L1=	4	ft		M =	11,554 lb-ft
L2=	2	ft		Fb =	1,686 psi
X=	3.3	ft		Fv =	193 psi
P=	5,314	lbs		$\Delta$ =	0.09 in
b=	3.50	in		I/	818
d=	11.88	in		Cv=	1.00
E=	1,500	ksi			

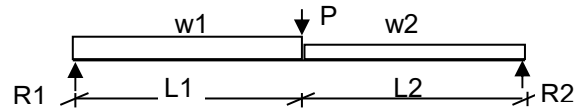

Beam		U5		GL 5 1/2x24	
w1=	880	plf		R1 =	15,361 lbs
w2=	1,518	plf		R2 =	15,777 lbs
L1=	5	ft		M =	81,543 lb-ft
L2=	16	ft		Fb =	1,853 psi
X=	10.0	ft		Fv =	155 psi
P=	3,270	lbs		$\Delta$ =	0.53 in
b=	5.50	in		I/	456
d=	24.00	in		Cv=	0.93
E=	1,800	ksi			

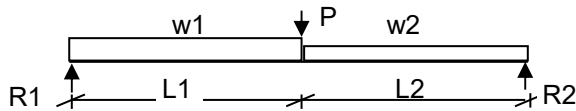

Beam		U8		GL 5 1/2x12	
w=	500	plf		R=	3,500 lbs
L=	14	ft		M=	12,250 ft-lbs
b=	5.50	in		Fb=	1,114 psi
d=	12.00	in		Fv=	68 psi
E=	1800	ksi		$\Delta$ =	0.30 in
Cv=	1.00	$\leq 1.0$		I/	554

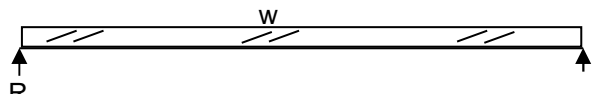

**STRUCTURAL  
ENGINEERING**

2124 Third Avenue . Suite 100 . Seattle . WA 98121  
www.swensonsayfaget.com

Office: 206.443.6212  
Fax: 206.443.4870

Project: Rainer 9118 Date: 08/25/21

Mercer Island, Washington Project #: \_\_\_\_\_

Upper Floor Framing Design: JDT

Sheet: G6

Header		U9		4x12	
w=	480	plf		R=	1,980 lbs
L=	8.25	ft		M=	4,084 ft-lbs
b=	3.50	in		Fb=	664 psi
d=	11.25	in		Fv=	58 psi
E=	1700	ksi		$\Delta$ =	0.07 in
Cv=	1.00	$\leq 1.0$		I/	1397

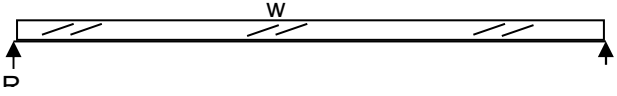

Beam		U12		LSL 3 1/2x16	
w1=	80	plf		R1=	1,752 lbs
w2=	627	plf		R2=	3,814 lbs
L1=	8	ft		M=	11,459 lb-ft
L2=	7	ft		Fb=	921 psi
X=	7.8	ft		Fv=	80 psi
P=	694	lbs		$\Delta$ =	0.23 in
b=	3.50	in		I/	758
d=	16.00	in		Cv=	1.00
E=	1,500	ksi			

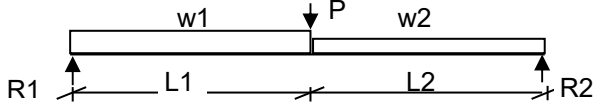

Beam		U10		P.T. 6x12	
w=	187	plf		R=	1,356 lbs
L=	14.5	ft		M=	4,915 ft-lbs
b=	5.50	in		Fb=	486 psi
d=	11.50	in		Fv=	28 psi
E=	1300	ksi		$\Delta$ =	0.21 in
Cv=	1.00	$\leq 1.0$		I/	848

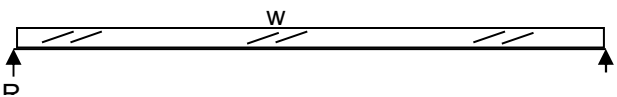

Beam		U13		LSL 3 1/2x16	
w1=	627	plf		R1=	2587 lbs
w2=	627	plf		R2=	4,935 lbs
L1=	9	ft		M+=	5,336 lb-ft
L2=	2	ft		M-=	2,112 lb-ft
X=	4.50	ft		Fb=	429 psi
P=	938	lbs		Fv=	59 psi
b=	3.50	in		$\Delta$ span=	0.041 in
d=	16.00	in		I span/	2,613
E=	1,500	ksi		$\Delta$ cant=	(0.02) in
Cv=	1.00			I cant/	(2,120)

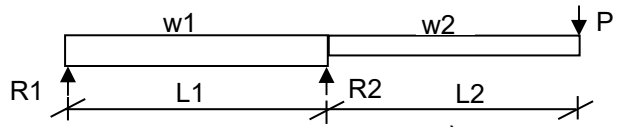

Beam		U11		LSL 3 1/2x16	
w=	955	plf		R=	6,327 lbs
L=	13.25	ft		M=	20,958 ft-lbs
b=	3.50	in		Fb=	1,684 psi
d=	16.00	in		Fv=	135 psi
E=	1500	ksi		$\Delta$ =	0.37 in
Cv=	1.00	$\leq 1.0$		I/	430

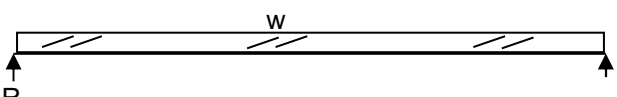

Beam		U14		GL 5 1/2x24	
w=	1005	plf		R=	9,045 lbs
L=	18	ft		M=	40,703 ft-lbs
b=	5.50	in		Fb=	925 psi
d=	24.00	in		Fv=	80 psi
E=	1800	ksi		$\Delta$ =	0.21 in
Cv=	0.94	$\leq 1.0$		I/	1038

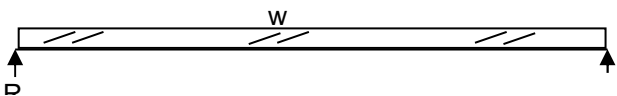

Beam		U14		GL 5 1/2x24	
w=	1005	plf		R=	9,045 lbs
L=	18	ft		M=	40,703 ft-lbs
b=	5.50	in		Fb=	925 psi
d=	24.00	in		Fv=	80 psi
E=	1800	ksi		$\Delta$ =	0.21 in
Cv=	0.94	$\leq 1.0$		I/	1038

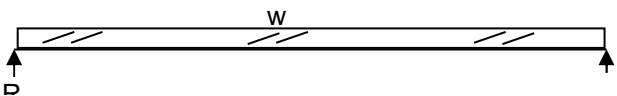
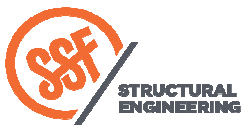
**STRUCTURAL  
ENGINEERING**

2124 Third Avenue . Suite 100 . Seattle . WA 98121  
www.swensonsayfaget.com

Office: 206.443.6212  
Fax: 206.443.4870

Project: Rainer 9118 Date: 08/25/21

Mercer Island, Washington Project #: \_\_\_\_\_

Upper Floor Framing Design: JDT

Sheet: G7

Header		U15	GL 5 1/2x24
w1=	260	plf	R1 = 6,928 lbs
w2=	180	plf	R2 = 7,258 lbs
L1=	13	ft	M = 66,281 lb-ft
L2=	11	ft	Fb = 1,506 psi
X=	11.8	ft	Fv = 78 psi
P=	9,045	lbs	$\Delta$ = 0.47 in
b=	5.50	in	I / 589
d=	24.00	in	Cv = 0.92
E=	1,800	ksi	

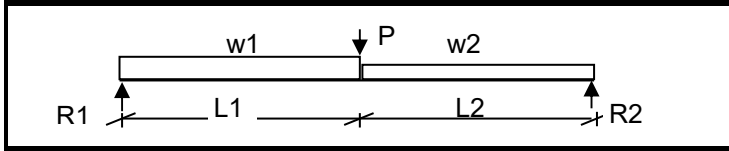

Header		U16	GL 3 1/2x12
w=	140	plf	R= 1,155 lbs
L=	16.5	ft	M= 4,764 ft-lbs
b=	3.50	in	Fb= 681 psi
d=	12.00	in	Fv= 36 psi
E=	1800	ksi	$\Delta$ = 0.26 in
Cv=	1.00	$\leq 1.0$	I / 769

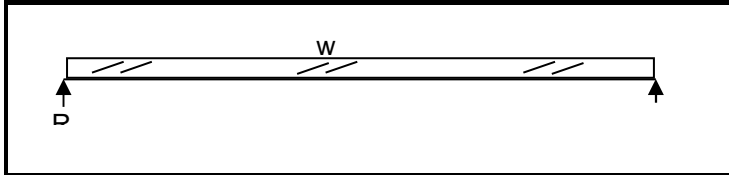

**STRUCTURAL  
ENGINEERING**

2124 Third Avenue . Suite 100 . Seattle . WA 98121  
www.swensonsayfaget.com

Office: 206.443.6212  
Fax: 206.443.4870

Project: Rainer 9118 Date: 08/25/21  
Mercer Island, Washington Project #: \_\_\_\_\_  
Upper Floor Framing Design: JDT  
 \_\_\_\_\_ Sheet: G8

GRAVITY DESIGN KEY PLAN

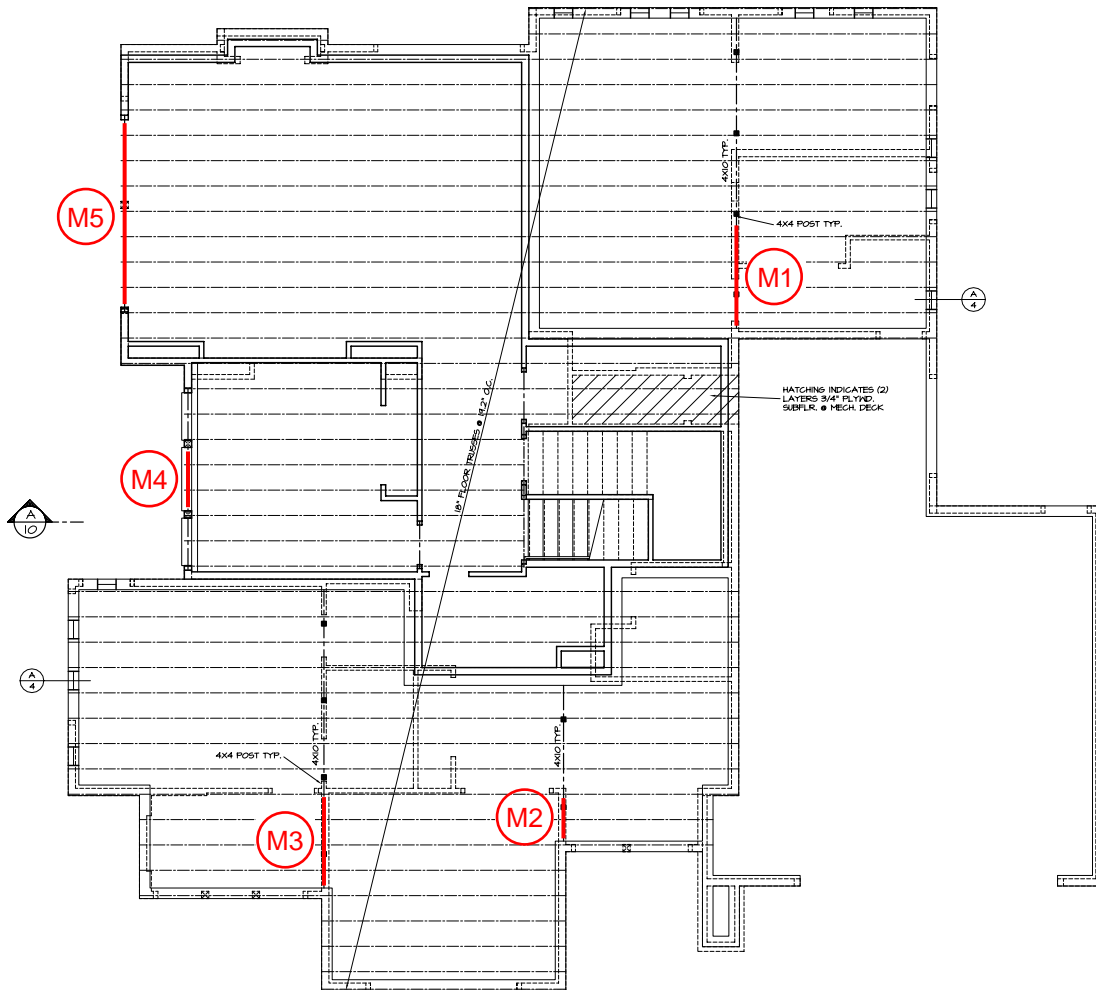

MAIN FLOOR FRAMING PLAN

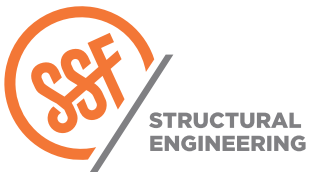

**RAINIER 9118**

PROJECT  
**MERCER ISLAND, WASHINGTON**

DATE

PROJ. # **JDT**

DESIGN **G9**

SHEET

Beam		M1		LSL 3 1/2x9 1/2	
w1=	2,185	plf		R1=	3687 lbs
w2=	2,185	plf		R2=	11,062 lbs
L1=	5	ft		M+=	3,111 lb-ft
L2=	2	ft		M-=	5,531 lb-ft
X=	2.25	ft		Fb=	1,261 psi
P=	-	lbs		Fv=	199 psi
b=	3.50	in		$\Delta$ span=	0.021 in
d=	9.50	in		I span/	2,512
E=	1,500	ksi		$\Delta$ cant=	0.03 in
Cv=	1.00			I cant/	1,675

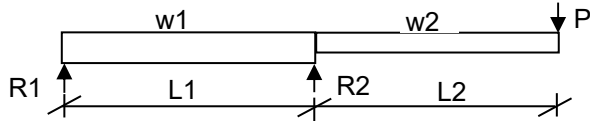

Header		M4		4x10	
w=	1270	plf		R=	2,858 lbs
L=	4.5	ft		M=	3,215 ft-lbs
b=	3.50	in		Fb=	773 psi
d=	9.25	in		Fv=	87 psi
E=	1700	ksi		$\Delta$ =	0.03 in
Cv=	1.00	$\leq 1.0$		I/	1808

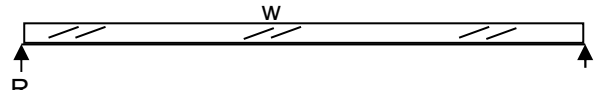

Beam		M2		LSL 3 1/2x9 1/2	
w1=	1,105	plf		R1 =	3,791 lbs
w2=	1,305	plf		R2 =	6,677 lbs
L1=	3	ft		M =	6,025 lb-ft
L2=	1	ft		Fb =	1,373 psi
X=	2.0	ft		Fv =	255 psi
P=	6,401	lbs		$\Delta$ =	0.03 in
b=	3.50	in		I/	1,381
d=	9.50	in		Cv=	1.00
E=	1,500	ksi			

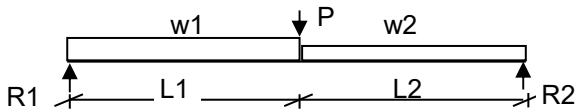

Header		M5		PSL 3 1/2x18	
w1=	755	plf		R1 =	6,677 lbs
w2=	755	plf		R2 =	6,297 lbs
L1=	6	ft		M =	25,307 lb-ft
L2=	7	ft		Fb =	1,607 psi
X=	6.0	ft		Fv =	132 psi
P=	3,726	lbs		$\Delta$ =	0.17 in
b=	3.50	in		I/	879
d=	18.00	in		Cv=	1.00
E=	2,200	ksi			

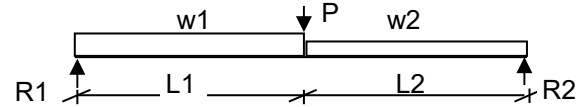

Beam		M3		LSL 3 1/2x9 1/2	
w1=	1,415	plf		R1 =	5,677 lbs
w2=	1,415	plf		R2 =	5,273 lbs
L1=	3	ft		M =	9,770 lb-ft
L2=	4	ft		Fb =	2,227 psi
X=	3.3	ft		Fv =	206 psi
P=	1,752	lbs		$\Delta$ =	0.19 in
b=	3.50	in		I/	401
d=	9.50	in		Cv=	1.00
E=	1,500	ksi			

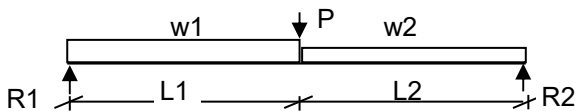

STRUCTURAL  
ENGINEERING

2124 Third Avenue . Suite 100 . Seattle . WA 98121  
www.swensonsayfaget.com

Office: 206.443.6212  
Fax: 206.443.4870

Project: Rainer 9118 Date: 08/26/21

Mercer Island, Washington Project #:

Main Floor Framing Design: JDT

Sheet: G10



GRAVITY DESIGN

FOUNDATION DESIGN

F1:

P = 13,532#  
qallow = 2,000 psf  
Areq = 6.8 square feet

USE 3'-0"x3'-0"x12" DEEP CONCRETE PAD FOOTING WITH (4)#4's EACH WAY BOTTOM

F2:

P = 28,563#  
qallow = 2,000 psf  
Areq = 14.3 square feet

USE 4'-0"x4'-0"x14" DEEP CONCRETE PAD FOOTING WITH (4)#4's EACH WAY TOP AND BOTTOM

F3:

P = 4,883#  
qallow = 2,000 psf  
Areq = 2.4 square feet

USE 2'-0"x2'-0"x10" DEEP CONCRETE PAD FOOTING WITH (3)#4's EACH WAY BOTTOM

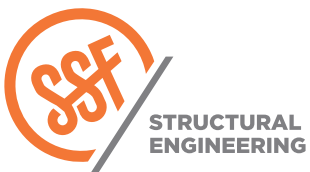

RAINIER 9118

MERCER ISLAND, WASHINGTON

DATE

PROJ. # JDT

DESIGN G12

SHEET

Use menu item Settings > Printing & Title Block  
to set these five lines of information  
for your program.

Project Name/Number : Typical Detail

Title Retaining Wall Schedule

Dsgnr: JDT  
Description....

10'-0" Retaining Wall w/ Slab, w/ Seismic

Page : 1  
Date: 26 AUG 2021

This Wall in File: C:\Users\jtreault\Desktop\Rainier 9118\Typical Detail Co-04-07.RPX

RetainPro (c) 1987-2019, Build 11.20.03.31  
License : KW-06052576  
License To : SWENSON SAY FAGET

### Cantilevered Retaining Wall

Code: IBC 2018, ACI 318-14, TMS 402-16

#### Criteria

Retained Height	=	10.00 ft
Wall height above soil	=	0.00 ft
Slope Behind Wall	=	0.00
Height of Soil over Toe	=	6.00 in
Water height over heel	=	0.0 ft

#### Soil Data

Allow Soil Bearing	=	2,667.0 psf
Equivalent Fluid Pressure Method		
Active Heel Pressure	=	35.0 psf/ft
	=	
Passive Pressure	=	300.0 psf/ft
Soil Density, Heel	=	125.00 pcf
Soil Density, Toe	=	0.00 pcf
Footing  Soil Friction	=	0.350
Soil height to ignore for passive pressure	=	12.00 in

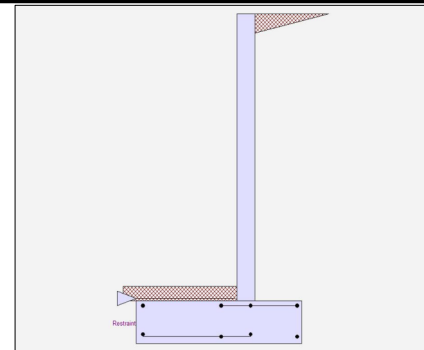

#### Surcharge Loads

Surcharge Over Heel	=	0.0 psf
Used To Resist Sliding & Overturning		
Surcharge Over Toe	=	0.0
Used for Sliding & Overturning		

#### Lateral Load Applied to Stem

Lateral Load	=	0.0 #/ft
...Height to Top	=	0.00 ft
...Height to Bottom	=	0.00 ft
Load Type	=	Wind (W) (Service Level)
Wind on Exposed Stem	=	0.0 psf (Service Level)

#### Adjacent Footing Load

Adjacent Footing Load	=	0.0 lbs
Footing Width	=	0.00 ft
Eccentricity	=	0.00 in
Wall to Ftg CL Dist	=	0.00 ft
Footing Type	=	Line Load
Base Above/Below Soil at Back of Wall	=	0.0 ft
Poisson's Ratio	=	0.300

#### Axial Load Applied to Stem

Axial Dead Load	=	0.0 lbs
Axial Live Load	=	0.0 lbs
Axial Load Eccentricity	=	0.0 in

#### Earth Pressure Seismic Load

Method : Uniform		
Multiplier Used	=	8.000
(Multiplier used on soil density)		
Uniform Seismic Force	=	92.000
Total Seismic Force	=	1,058.000

#### Design Summary

##### Wall Stability Ratios

Overturning	=	1.52 OK
Slab Resists All Sliding !		
Total Bearing Load	=	4,580 lbs
...resultant ecc.	=	19.11 in
Soil Pressure @ Toe	=	2,045 psf OK
Soil Pressure @ Heel	=	0 psf OK
Allowable	=	2,667 psf
Soil Pressure Less Than Allowable		
ACI Factored @ Toe	=	2,863 psf
ACI Factored @ Heel	=	0 psf
Footing Shear @ Toe	=	24.6 psi OK
Footing Shear @ Heel	=	16.7 psi OK
Allowable	=	75.0 psi

##### Sliding Calcs

Lateral Sliding Force	=	3,055.0 lbs
-----------------------	---	-------------

#### Stem Construction

Design Height Above Ftg	ft =	0.00
Wall Material Above "Ht"	=	Concrete
Design Method	=	LRFD
Thickness	=	8.00
Rebar Size	=	# 5
Rebar Spacing	=	6.00
Rebar Placed at	=	Edge

##### Design Data

fb/FB + fa/Fa	=	0.915
---------------	---	-------

##### Total Force @ Section

Service Level	lbs =	
Strength Level	lbs =	3,720.0

##### Moment....Actual

Service Level	ft-# =	
Strength Level	ft-# =	13,933.3
Moment.....Allowable	=	15,222.0

##### Shear.....Actual

Service Level	psi =	
Strength Level	psi =	50.1
Shear.....Allowable	psi =	75.0
Anet (Masonry)	in2 =	
Rebar Depth 'd'	in =	6.19

##### Masonry Data

f'm	psi =	
Fs	psi =	
Solid Grouting	=	
Modular Ratio 'n'	=	
Wall Weight	psf =	100.0
Short Term Factor	=	
Equiv. Solid Thick.	=	
Masonry Block Type	=	Medium Weight
Masonry Design Method	=	ASD

##### Concrete Data

f'c	psi =	2,500.0
Fy	psi =	60,000.0

Vertical component of active lateral soil pressure IS  
NOT considered in the calculation of soil bearing

##### Load Factors

Building Code	IBC 2018, ACI
Dead Load	1.200
Live Load	1.600
Earth, H	1.600
Wind, W	1.000
Seismic, E	1.000



Use menu item Settings > Printing & Title Block  
to set these five lines of information  
for your program.

Project Name/Number : Typical Detail

Title Retaining Wall Schedule

Dsgnr: JDT

Description....

10'-0" Retaining Wall w/ Slab, w/ Seismic

Page : 2  
Date: 26 AUG 2021

This Wall in File: C:\Users\jtetreault\Desktop\Rainier 9118\Typical Detail Co-04-07.RPX

RetainPro (c) 1987-2019, Build 11.20.03.31  
License : KW-06052576  
License To : SWENSON SAY FAGET

### Cantilevered Retaining Wall

Code: IBC 2018,ACI 318-14,TMS 402-16

#### Concrete Stem Rebar Area Details

Bottom Stem	Vertical Reinforcing	Horizontal Reinforcing	
As (based on applied moment) :	0.5276 in <sup>2</sup> /ft		
(4/3) * As :	0.7035 in <sup>2</sup> /ft	Min Stem T&S Reinf Area 1.920 in <sup>2</sup>	
200bd/fy : 200(12)(6.1875)/60000 :	0.2475 in <sup>2</sup> /ft	Min Stem T&S Reinf Area per ft of stem Height : 0.192 in <sup>2</sup> /ft	
0.0018bh : 0.0018(12)(8) :	0.1728 in <sup>2</sup> /ft	Horizontal Reinforcing Options :	
	=====	One layer of :	Two layers of :
Required Area :	0.5276 in <sup>2</sup> /ft	#4@ 12.50 in	#4@ 25.00 in
Provided Area :	0.62 in <sup>2</sup> /ft	#5@ 19.38 in	#5@ 38.75 in
Maximum Area :	0.8382 in <sup>2</sup> /ft	#6@ 27.50 in	#6@ 55.00 in

#### Footing Data

Toe Width	=	3.75 ft
Heel Width	=	2.42
Total Footing Width	=	6.17
Footing Thickness	=	18.00 in
Key Width	=	0.00 in
Key Depth	=	0.00 in
Key Distance from Toe	=	0.00 ft
f <sub>c</sub> =	2,500 psi	F <sub>y</sub> = 60,000 psi
Footing Concrete Density	=	150.00 pcf
Min. As %	=	0.0018
Cover @ Top	2.00	@ Btm.= 3.00 in

#### Footing Design Results

	<u>Toe</u>	<u>Heel</u>
Factored Pressure	= 2,863	0 psf
Mu' : Upward	= 174,166	0 ft-#
Mu' : Downward	= 29,109	2,721 ft-#
Mu: Design	= 12,088	2,721 ft-#
Actual 1-Way Shear	= 24.55	16.68 psi
Allow 1-Way Shear	= 75.00	75.00 psi
Toe Reinforcing	= # 5 @ 6.00 in	
Heel Reinforcing	= # 5 @ 9.00 in	
Key Reinforcing	= None Spec'd	
Footing Torsion, Tu	=	0.00 ft-lbs
Footing Allow. Torsion, phi Tu	=	0.00 ft-lbs

**If torsion exceeds allowable, provide supplemental design for footing torsion.**

Other Acceptable Sizes & Spacings

Toe: #4@ 6.17 in, #5@ 9.56 in, #6@ 13.58 in, #7@ 18.51 in, #8@ 24.38 in, #9@ 30.  
Heel: #4@ 6.17 in, #5@ 9.56 in, #6@ 13.58 in, #7@ 18.51 in, #8@ 24.38 in, #9@ 30.  
Key: No key defined

Min footing T&S reinf Area	2.40	in <sup>2</sup>
Min footing T&S reinf Area per foot	0.39	in <sup>2</sup> /ft
If one layer of horizontal bars:		If two layers of horizontal bars:
#4@ 6.17 in		#4@ 12.35 in
#5@ 9.57 in		#5@ 19.14 in
#6@ 13.58 in		#6@ 27.16 in

Use menu item Settings > Printing & Title Block  
to set these five lines of information  
for your program.

Project Name/Number : Typical Detail

Title Retaining Wall Schedule

Dsgnr: JDT  
Description....

10'-0" Retaining Wall w/ Slab, w/ Seismic

Page : 3  
Date: 26 AUG 2021

This Wall in File: C:\Users\jtreault\Desktop\Rainier 9118\Typical Detail Co-04-07.RPX

RetainPro (c) 1987-2019, Build 11.20.03.31  
License : KW-06052576  
License To : SWENSON SAY FAGET

## Cantilevered Retaining Wall

Code: IBC 2018,ACI 318-14,TMS 402-16

### Summary of Overturning & Resisting Forces & Moments

Item	.....OVERTURNING.....			.....RESISTING.....			
	Force lbs	Distance ft	Moment ft-#	Force lbs	Distance ft	Moment ft-#	
HL Act Pres (ab water tbl)	2,314.4	3.83	8,871.8	Soil Over HL (ab. water tbl)	2,191.7	5.29	11,601.2
HL Act Pres (be water tbl)				Soil Over HL (bel. water tbl)		5.29	11,601.2
Hydrostatic Force				Watre Table			
Buoyant Force =				Sloped Soil Over Heel =			
Surcharge over Heel =				Surcharge Over Heel =			
Surcharge Over Toe =				Adjacent Footing Load =			
Adjacent Footing Load =				Axial Dead Load on Stem =			
Added Lateral Load =				* Axial Live Load on Stem =			
Load @ Stem Above Soil =				Soil Over Toe =		1.88	
Seismic Earth Load =	740.6	5.75	4,258.5	Surcharge Over Toe =			
=				Stem Weight(s) =	1,000.0	4.08	4,083.3
<b>Total</b> =	<b>3,055.0</b>	<b>O.T.M.</b>	<b>= 13,130.2</b>	Earth @ Stem Transitions =			
				Footing Weight =	1,388.3	3.09	4,282.8
				Key Weight =			
				Vert. Component =			
<b>Resisting/Overturning Ratio</b>			<b>= 1.52</b>	<b>Total =</b>	<b>4,579.9 lbs</b>	<b>R.M.=</b>	<b>19,967.3</b>
Vertical Loads used for Soil Pressure =		4,579.9 lbs					

\* Axial live load NOT included in total displayed, or used for overturning resistance, but is included for soil pressure calculation.

If seismic is included, the OTM and sliding ratios may be 1.1 per section 1807.2.3 of IBC.

Vertical component of active lateral soil pressure IS NOT considered in the calculation of Sliding Resistance.

Vertical component of active lateral soil pressure IS NOT considered in the calculation of Overturning Resistance.

### Tilt

#### Horizontal Deflection at Top of Wall due to settlement of soil

(Deflection due to wall bending not considered)

Soil Spring Reaction Modulus 250.0 pci  
Horizontal Defl @ Top of Wall (approximate only) 0.092 in

The above calculation is not valid if the heel soil bearing pressure exceeds that of the toe, because the wall would then tend to rotate into the retained soil.

Use menu item **Settings > Printing & Title Block**  
to set these five lines of information  
for your program.

Project Name/Number : Typical Detail

Title **Retaining Wall Schedule**

Dsgnr: **JDT**  
Description....

**11'-6" Retaining Wall w/ Slab**

Page : 1  
Date: 26 AUG 2021

This Wall in File: C:\Users\jtreault\Desktop\Rainier 9118\Typical Detail Co-04-07.RPX

RetainPro (c) 1987-2019, Build 11.20.03.31  
License : KW-06052576  
License To : SWENSON SAY FAGET

### Cantilevered Retaining Wall

Code: IBC 2018, ACI 318-14, TMS 402-16

#### Criteria

Retained Height	=	11.50 ft
Wall height above soil	=	0.00 ft
Slope Behind Wall	=	0.00
Height of Soil over Toe	=	6.00 in
Water height over heel	=	0.0 ft

#### Soil Data

Allow Soil Bearing	=	2,000.0 psf
Equivalent Fluid Pressure Method		
Active Heel Pressure	=	35.0 psf/ft
Passive Pressure	=	300.0 psf/ft
Soil Density, Heel	=	125.00 pcf
Soil Density, Toe	=	0.00 pcf
Footings  Soil Friction	=	0.350
Soil height to ignore for passive pressure	=	12.00 in

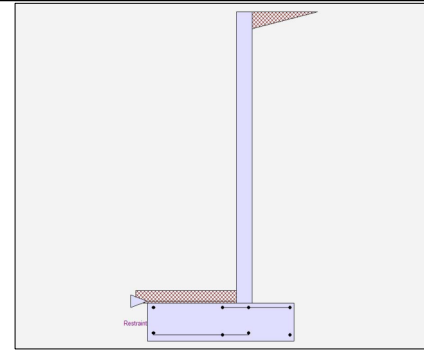

#### Surcharge Loads

Surcharge Over Heel	=	0.0 psf
Used To Resist Sliding & Overturning		
Surcharge Over Toe	=	0.0
Used for Sliding & Overturning		

#### Lateral Load Applied to Stem

Lateral Load	=	0.0 #/ft
...Height to Top	=	0.00 ft
...Height to Bottom	=	0.00 ft
Load Type	=	Wind (W) (Service Level)
Wind on Exposed Stem	=	0.0 psf (Service Level)

#### Adjacent Footing Load

Adjacent Footing Load	=	0.0 lbs
Footing Width	=	0.00 ft
Eccentricity	=	0.00 in
Wall to Ftg CL Dist	=	0.00 ft
Footing Type	=	Line Load
Base Above/Below Soil at Back of Wall	=	0.0 ft
Poisson's Ratio	=	0.300

#### Axial Load Applied to Stem

Axial Dead Load	=	0.0 lbs
Axial Live Load	=	0.0 lbs
Axial Load Eccentricity	=	0.0 in

#### Design Summary

##### Wall Stability Ratios

Overturning	=	1.74 OK
Slab Resists All Sliding !		

Total Bearing Load	=	5,059 lbs
...resultant ecc.	=	14.47 in

Soil Pressure @ Toe	=	1,795 psf OK
Soil Pressure @ Heel	=	0 psf OK
Allowable	=	2,000 psf
Soil Pressure Less Than Allowable		

ACI Factored @ Toe	=	2,513 psf
ACI Factored @ Heel	=	0 psf
Footing Shear @ Toe	=	23.0 psi OK
Footing Shear @ Heel	=	17.0 psi OK
Allowable	=	75.0 psi

##### Sliding Calcs

Lateral Sliding Force	=	2,957.5 lbs
-----------------------	---	-------------

Vertical component of active lateral soil pressure IS NOT considered in the calculation of soil bearing

##### Load Factors

Building Code	IBC 2018, ACI
Dead Load	1.200
Live Load	1.600
Earth, H	1.600
Wind, W	1.000
Seismic, E	1.000

#### Stem Construction

Design Height Above Ftg	ft =	0.00
Wall Material Above "Ht"	=	Concrete
Design Method	=	LRFD
Thickness	=	8.00
Rebar Size	=	# 5
Rebar Spacing	=	6.00
Rebar Placed at	=	Edge

##### Design Data

fb/FB + fa/Fa	=	0.932
---------------	---	-------

##### Total Force @ Section

Service Level	lbs =	
Strength Level	lbs =	3,703.0

##### Moment....Actual

Service Level	ft-# =	
Strength Level	ft-# =	14,194.8
Moment....Allowable	=	15,222.0

##### Shear....Actual

Service Level	psi =	
Strength Level	psi =	49.9
Shear....Allowable	psi =	75.0
Anet (Masonry)	in2 =	
Rebar Depth 'd'	in =	6.19

##### Masonry Data

f <sub>m</sub>	psi =	
F <sub>s</sub>	psi =	
Solid Grouting	=	
Modular Ratio 'n'	=	
Wall Weight	psf =	100.0
Short Term Factor	=	
Equiv. Solid Thick.	=	
Masonry Block Type	=	Medium Weight
Masonry Design Method	=	ASD

##### Concrete Data

f <sub>c</sub>	psi =	2,500.0
F <sub>y</sub>	psi =	60,000.0

Use menu item Settings > Printing & Title Block  
to set these five lines of information  
for your program.

Project Name/Number : Typical Detail

Title Retaining Wall Schedule

Dsgnr: JDT  
Description....

11'-6" Retaining Wall w/ Slab

Page : 2  
Date: 26 AUG 2021

This Wall in File: C:\Users\jtetreault\Desktop\Rainier 9118\Typical Detail Co-04-07.RPX

RetainPro (c) 1987-2019, Build 11.20.03.31  
License : KW-06052576  
License To : SWENSON SAY FAGET

### Cantilevered Retaining Wall

Code: IBC 2018,ACI 318-14,TMS 402-16

#### Concrete Stem Rebar Area Details

Bottom Stem	Vertical Reinforcing	Horizontal Reinforcing
As (based on applied moment) :	0.5375 in <sup>2</sup> /ft	
(4/3) * As :	0.7167 in <sup>2</sup> /ft	Min Stem T&S Reinf Area 2.208 in <sup>2</sup>
200bd/fy : 200(12)(6.1875)/60000 :	0.2475 in <sup>2</sup> /ft	Min Stem T&S Reinf Area per ft of stem Height : 0.192 in <sup>2</sup> /ft
0.0018bh : 0.0018(12)(8) :	0.1728 in <sup>2</sup> /ft	Horizontal Reinforcing Options :
	=====	One layer of :      Two layers of :
Required Area :	0.5375 in <sup>2</sup> /ft	#4@ 12.50 in      #4@ 25.00 in
Provided Area :	0.62 in <sup>2</sup> /ft	#5@ 19.38 in      #5@ 38.75 in
Maximum Area :	0.8382 in <sup>2</sup> /ft	#6@ 27.50 in      #6@ 55.00 in

#### Footing Data

Toe Width	=	3.75 ft
Heel Width	=	2.42
Total Footing Width	=	6.17
Footing Thickness	=	18.00 in
Key Width	=	0.00 in
Key Depth	=	0.00 in
Key Distance from Toe	=	0.00 ft
f <sub>c</sub> =	2,500 psi	F <sub>y</sub> = 60,000 psi
Footing Concrete Density	=	150.00 pcf
Min. As %	=	0.0018
Cover @ Top	2.00	@ Btm.= 3.00 in

#### Footing Design Results

	Toe	Heel
Factored Pressure	= 2,513	0 psf
Mu' : Upward	= 165,012	135 ft-#
Mu' : Downward	= 29,109	3,066 ft-#
Mu: Design	= 11,325	2,932 ft-#
Actual 1-Way Shear	= 23.03	17.02 psi
Allow 1-Way Shear	= 75.00	75.00 psi
Toe Reinforcing	= # 5 @ 6.00 in	
Heel Reinforcing	= # 5 @ 9.00 in	
Key Reinforcing	= None Spec'd	
Footing Torsion, Tu	=	0.00 ft-lbs
Footing Allow. Torsion, phi Tu	=	0.00 ft-lbs

**If torsion exceeds allowable, provide supplemental design for footing torsion.**

#### Other Acceptable Sizes & Spacings

Toe: #4@ 6.17 in, #5@ 9.56 in, #6@ 13.58 in, #7@ 18.51 in, #8@ 24.38 in, #9@ 30.  
Heel: #4@ 6.17 in, #5@ 9.56 in, #6@ 13.58 in, #7@ 18.51 in, #8@ 24.38 in, #9@ 30.  
Key: No key defined

Min footing T&S reinf Area	2.40	in <sup>2</sup>
Min footing T&S reinf Area per foot	0.39	in <sup>2</sup> /ft
If one layer of horizontal bars:		If two layers of horizontal bars:
#4@ 6.17 in		#4@ 12.35 in
#5@ 9.57 in		#5@ 19.14 in
#6@ 13.58 in		#6@ 27.16 in

Use menu item Settings > Printing & Title Block  
to set these five lines of information  
for your program.

Project Name/Number : Typical Detail

Title Retaining Wall Schedule

Dsgnr: JDT

Description....

11'-6" Retaining Wall w/ Slab

Page : 3  
Date: 26 AUG 2021

This Wall in File: C:\Users\jtreault\Desktop\Rainier 9118\Typical Detail Co-04-07.RPX

RetainPro (c) 1987-2019, Build 11.20.03.31  
License : KW-06052576  
License To : SWENSON SAY FAGET

### Cantilevered Retaining Wall

Code: IBC 2018, ACI 318-14, TMS 402-16

#### Summary of Overturning & Resisting Forces & Moments

Item	.....OVERTURNING.....			.....RESISTING.....			
	Force lbs	Distance ft	Moment ft-#	Force lbs	Distance ft	Moment ft-#	
HL Act Pres (ab water tbl)	2,957.5	4.33	12,815.8	Soil Over HL (ab. water tbl)	2,520.4	5.29	13,341.4
HL Act Pres (be water tbl)				Soil Over HL (bel. water tbl)		5.29	13,341.4
Hydrostatic Force				Watre Table			
Buoyant Force =				Sloped Soil Over Heel =			
Surcharge over Heel =				Surcharge Over Heel =			
Surcharge Over Toe =				Adjacent Footing Load =			
Adjacent Footing Load =				Axial Dead Load on Stem =			
Added Lateral Load =				* Axial Live Load on Stem =			
Load @ Stem Above Soil =				Soil Over Toe =		1.88	
				Surcharge Over Toe =			
				Stem Weight(s) =	1,150.0	4.08	4,695.8
				Earth @ Stem Transitions =			
<b>Total</b>	= 2,957.5	<b>O.T.M.</b>	= 12,815.8	Footing Weight =	1,388.3	3.09	4,282.8
				Key Weight =			
				Vert. Component =			
<b>Resisting/Overturning Ratio</b>		=	<b>1.74</b>	<b>Total =</b>	<b>5,058.7 lbs</b>	<b>R.M.=</b>	<b>22,320.0</b>
Vertical Loads used for Soil Pressure =		5,058.7	lbs				

\* Axial live load NOT included in total displayed, or used for overturning resistance, but is included for soil pressure calculation.

Vertical component of active lateral soil pressure IS NOT considered in the calculation of Sliding Resistance.

Vertical component of active lateral soil pressure IS NOT considered in the calculation of Overturning Resistance.

#### Tilt

##### Horizontal Deflection at Top of Wall due to settlement of soil

(Deflection due to wall bending not considered)

Soil Spring Reaction Modulus 250.0 pci  
Horizontal Defl @ Top of Wall (approximate only) 0.093 in

The above calculation is not valid if the heel soil bearing pressure exceeds that of the toe, because the wall would then tend to rotate into the retained soil.